

Liberty Pumps®

SUMP JET® Water Powered Back-Up Pump

Model SJ10 Shown



SHARKBITE®
Fitting



Patent Pending



Patent Pending

**Protects
basement during
power outages!**

**Requires no
electricity**

Features:

- Accepts 20PSI up to 100PSI inlet supply pressure**
 - Fully automatic
 - High-output flow rates
 - Compact design
 - Fully-assembled
 - 1-1/2" Discharge
- Works off municipal water supply*
- 3/4" NPT water inlet connection
- UPC approved (IAPMO PS 119-2005)
- SHARKBITE® inlet connection accepts pex, copper or CTS CPVC 3/4" line

**Efficient design removes
more water per gallon used**

* The SJ10 requires an uninterrupted water source to operate. If you have a well pump, the SJ10 will not operate during power outages.

**SJ10 pumping performance varies with inlet water source pressure and pumping head. See complete specifications and performance chart for expected flow rates.

SHARKBITE® is a registered trademark of the CASH ACME Co.

NEW! SJ10A Pump with Alarm

Audible and visual alarm warns you when your water-powered back-up pump is activated. 120V with 9V battery backup.

innovate. evolve.

SUMPJET® Water Powered Back-Up Sump Pump

Performance Chart:

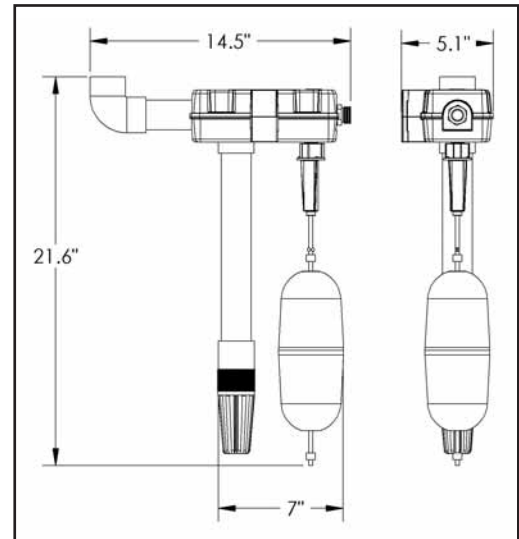
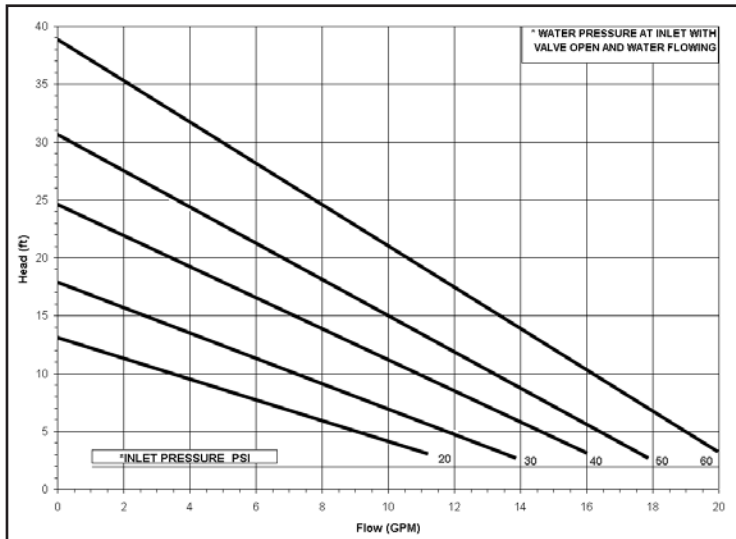

Water pressure valve at inlet with valve open and water flowing		Sump Water Removal At Various Heads (Static Head in 1-1/2" Pipe or Larger)													
Lift		4 ft.		1.21 m	8 ft.		2.4 M	12 ft.		3.6 M	15 ft.		4.5 M		
PSI	KPA	GPM	GPH	M ³ /hr	GPM	GPH	M ³ /hr	GPM	GPH	M ³ /hr	GPM	GPH	M ³ /hr	M ³ /hr	
20	138	11.0	660	2.5	5.8	348	1.3	-	-	-	-	-	-	-	
30	207	12.8	765	2.9	9	540	2.0	5.5	330	1.2	-	-	-	-	
40	276	15.4	924	3.5	12.5	750	2.8	9.3	558	2.1	7.2	432	1.6	-	
50	345	17.2	1032	3.9	14.5	870	3.3	12	720	2.7	10	600	2.3	-	
60	414	19.8	1185	4.5	17	1020	3.9	15.2	912	3.5	13.5	810	3.1	-	

Features:

- Adjustable stainless hose clamp for easy mounting
- Removes 2 gallons of water for each 1 gallon used. (based on 5' lift)
- Fully assembled, compact design
- Built-in screen with removable foot valve
- Constructed of durable PVC

Dimensions

Major Height: 21.6", Major Width: 5.1", Weight: 3.5 lbs.

Construction: PVC

Maximum Fluid Temperature 130 Degrees F.

Inlet Connection:

3/4" SHARKBITE® fitting

Discharge Size: 1-1/2"

Built-in check valve at water inlet

Additional backflow protection is required. Check with local plumbing codes prior to installation.

Important: Minimum recommended pit diameter is 18". The SJ10 works in conjunction with your main sump pump. Make sure you have adequate pit size to properly install the SJ10 without float interference.

Typical Installation Diagram:

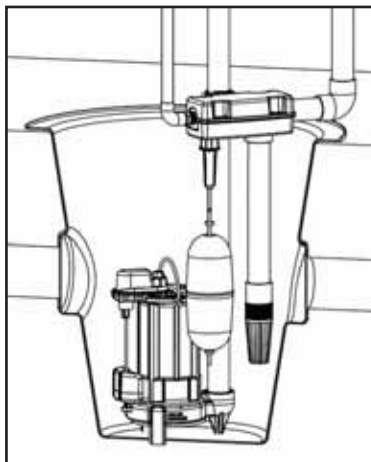

Sold Separately

Models

- SJ10** Standard water-powered backup pump (no alarm)
- SJ10A** Water-powered pump with alarm
- ADC-1** Automatic voice dialer (Optional, sold separately)

ADC-1 Auto Dialer sequentially dials any combination of four telephones, cell phones or pagers and delivers up to a 16 second recorded message - notifying you if your water pump is activated. Unit ties directly into the auxiliary contacts on the SJ10A alarm.

- Operating Voltage: 9-12 VDC
- Dimensions: 6" x 4" x 1.5"
- Mounting: Mounts flat on wall
- Record your own message
- Ability to program a pause and pound (#) tone in dialing sequence.

Call your cell phone

Call your plumbing contractor

Call your family

Call your neighbor